

Ring Shear Tester RST-XS.s

- smaller and more capabilities -

The Ring Shear Tester RST-XS.s is an easy to operate tester for the precise determination of flow properties of fine-grained powders and bulk solids. It has been developed with the aim to produce an even smaller and even more capable tester than ring shear tester RST-XS which has been successfully applied in research and industry since 2002.

The sample volume amounts to only 3.5 to 70 ml (depending on the shear cell, standard size 30 ml). Therefore, the RST-XS.s is appropriate especially for those industries and research institutions which deal with fine grained materials or which have only small amounts of powders for testing.

Capabilities and Application

The Ring Shear Tester RST-XS.s provides computer-controlled measurement of the flow properties of powders and other bulk solid materials, under conditions which duplicate handling situations. Such properties are useful for many applications:

- Product development,
- Product characterization,
- Quality control,
- Incoming control,
- Comparative tests,
- Troubleshooting,
- Design of silos and hoppers.

Ring shear testers are applied in various industries, e.g., in the pharmaceutical industry, food industry, or chemical industry, for materials such as inhaling powders, toner, cosmetics, construction materials, pigments, metal powders, spices, coal, powdered sugar, and many others.

Why are flow properties important?

A material's flow properties determine how it will behave in bins, hoppers, feeders, and other handling equipment. Knowing these properties is essential in product development, so that flow problems can be avoided [1].

Flow properties are also important for quality control. By checking the relative flow properties of a given bulk solid before it is placed into your system, you can reject and recycle unsatisfactory batches, thereby preventing costly handling problems from occurring downstream.

What flow properties need to be measured?

- Flowability (ff_c)
- Compressive strength (flow function)
- Time consolidation (increase of strength during storage at rest, "Caking")
- Wall friction (friction of a powder against a solid surface, e.g., stainless steel, coatings, linings)
- Bulk density, compressibility

With respect to comparative tests, quality control etc., **flowability ff_c** is the most important quantity.



● Ring shear tester RST-XS.s

Testing procedure

The powder sample is contained in an annular shear cell (see sketch). A vertical load F_N is applied through a thin loading rod on the annular lid. To shear the sample, the shear cell rotates relative to the lid (direction ω), and the torque necessary for shearing is determined from forces F_1 and F_2 acting in a tie rod and a push rod. Following a well-defined procedure, which is executed computer-controlled, the flow properties are measured.

All forces acting are transferred directly on the annular lid through thin rods. This ensures the accurate measurement of normal and shear forces without any friction forces having an influence on the test results.

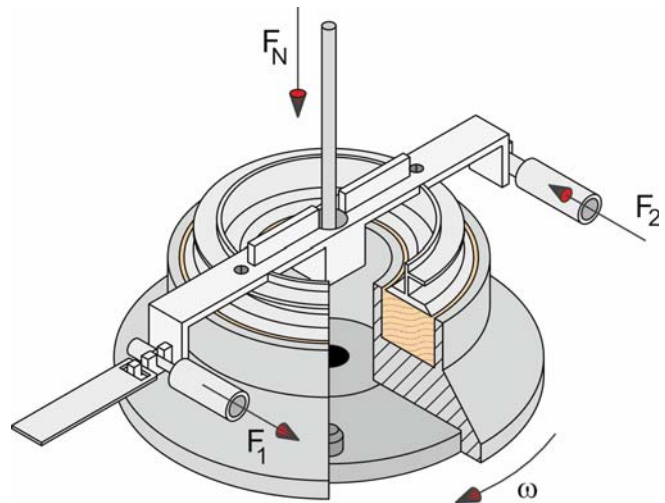

● Cut-away view of the shear cell (type XS-Mr, approx. 30 ml)

[1] D. Schulze: Powders and Bulk Solids, Springer-Verlag (2008)

[2] D. Schulze: Ringversuch mit Ringschergeräten, Schüttgut 16 (2010) 3, pp. 146–153

[3] D. Schulze: Round Robin Test on Ring Shear Testers, Advanced Powder Technology 22 (2011) 2, pp. 197–202



Primary operational components

- Automated application of vertical load, F_N .
- Digitally controlled motor drive for shear cell rotation
- Twin load beam system for accurate measurement of shear forces (F_1, F_2).
- Displacement transducer measures sample height for determination of bulk density and compressibility.
- Shear cell - Shear cells of different specimen volume (3.5 ml, 10 ml, 30 ml, 70 ml) and a wall friction cell are available. The wall friction cell can be equipped with custom-made wall material samples.
- NEW: "Low Stress" shear cell:** With this shear cell powders can be tested at very small normal stresses.



Shear cell approx. 30 ml, 2 EURO coin

Software

The control software RST-CONTROL 95 includes audio instructions to assist the operator allows remote operation of the Ring Shear Tester ("Test on a mouse click") as well as for the automatic evaluation of the test results. The software package additionally provides detailed analysis of test data and output of results, e.g. as diagram (see examples below) or table, with the possibility to export data/diagrams to other applications (e.g. word processor, spreadsheet).

- Yield locus diagram with flow properties

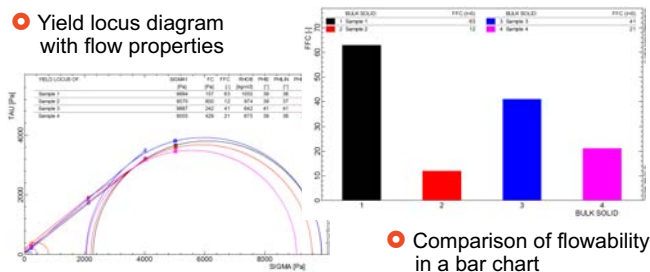

Comparison of flowability in a bar chart

Test procedures

- Yield locus test (flowability test)
- Time consolidation (Caking)
- Wall friction (wall yield locus)
- Influence of time on wall friction (time wall yield locus)
- Compressibility test
- Support of attrition tests
- NEW:** "Stress Walk": Multiple points of the flow function in one test.
- NEW:** Operator-controlled test
- NEW:** Elasticity test for materials with low elasticity

The control software RST-CONTROL 95 provides several modes of operation. For simplest operation standard procedures can be used ("One Click Test"). For more advanced application the detailed input of test parameters is possible.

* Windows 7, Windows 8, Windows 10 and Windows 11 are registered trademarks of Microsoft Corp., U.S.A.

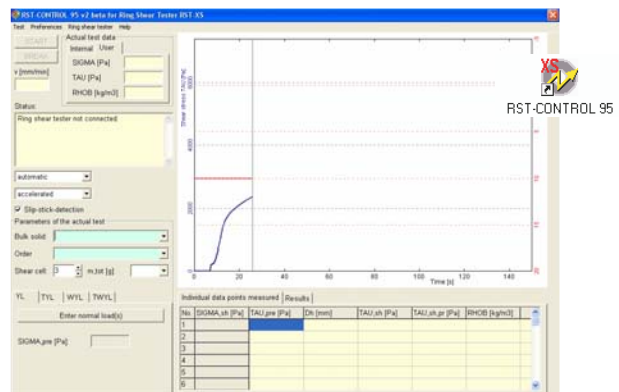

RST-CONTROL 95 (screen shot)

PC specifications for RST-CONTROL 95 software:

- Microsoft Windows 7/8/10/11*
- Serial communication port or USB port
- Screen resolution min. 1024x768
- Sound card / speaker for speech output

Ring shear tester RST-XS.s specifications

- Dimensions: 320 mm x 460 mm x 385 mm (W x H x D)
- Weight: ca. 23 kg
- Power requirements: 110V-240V, 50-60Hz, 80 W
- Normal stress up to 20 kPa (standard shear cell)
- Shear velocity approx. 0.025 to 15 mm/min (standard shear cell)
- Maximum particle size of specimen: Dependent on shear cell; with largest shear cell about 1.5 mm for broad particle size distributions; about 0.75 mm for narrow particle size distributions

Why choose Schulze Ring Shear Testers?

First, the automatic ring shear testers are easy to use, requiring minimal operator training and skill. In addition, the time required to test a material and analyze the results is also minimal.

Second, the testers are extremely versatile. Materials which are free flowing, very poor flowing, or require large shear deformation can all be tested. The applied stress level can be varied over a wide range, consistent with how your material is being handled.

Third, the testers are "Made in Germany". We have been developing and manufacturing ring shear testers for over 25 years. Every tester is assembled and tested individually. This ensures that each tester meets our stringent robustness and hard wearing criteria. We can also react with high flexibility to individual customers needs / requirements.

Fourth, our testers are the base for the acknowledged standard ASTM D6773 (Schulze Ring Shear Tester). Leading companies and research institutions on all five continents are using our ring shear tests.

Fifth, the results of an international round robin test [2,3] with ring shear testers RST-XS and RST-01.pc illustrate the high reproducibility between testers and data being user independent.

For coarser materials: Ring Shear Tester RST-01.pc

The large automatic Ring Shear Tester RST-01.pc provides specimen volumes up to 900 ml, which can be used for testing materials with particle sizes up to 5 ... 10 millimeters, depending on the width of the particle size distribution.

(c) 2022 Dr. Dietmar Schulze GmbH. All rights reserved. Technical modifications, errors and misprints excepted.



Dr. Dietmar Schulze
Powder testers & software

Dr. Dietmar Schulze GmbH, Am Forst 20, D-38302 Wolfenbüttel
Phone +49 5331 935 490, Fax +49 5331 978 001
mail@dietmar-schulze.de, www.dietmar-schulze.de